

# Operating Instructions and Parts List for No. H-24 24" Tile Cutter



*Quality Products Since 1927*

## **Beno J. Gundlach Company**

211 North 21st Street • P.O. Box 544  
Belleville, IL 62222 • U.S.A.

TEL: 618 233-1781 • FAX: 618 233-3636  
[www.benojgundlachco.com](http://www.benojgundlachco.com)

## Operating Instructions

**Note:** Casters (4 each) and mounting screws are supplied in a heavy duty paper bag in the carton with the cutter. When installing the casters, do not excessively tighten the screws, as this could strip the threads in the cutter base casting.

**WARNING:** The handle has 'spring tension return' action. Keep your head away from the travel path of the handle to avoid possible injury from a 'free flying' handle. There is no danger from this handle if kept under control by your hand.

**CAUTION:** This cutter has been designed to undercut the tile you are cutting. This feature gives a perfect seam when you butt the cut tile up against another tile. However, in order for this to occur, you must cut the tile top side up. If you have the bottom side up when cutting, you will leave an open seam when butting tiles together.

**CAUTION:** This cutter cannot be used for wood block tile. Also never use this cutter to cut metal.

## Information Regarding Shear Angle

The upper movable blade on this cutter (including the blade holding bar) can be adjusted to provide shear angle. The lower blade is stationary, and is not adjustable. Shear angle is the relationship between the cutting edges of the upper and lower blades. Zero shear angle is when these cutting edges are parallel.

Some types of tile can or should be cut with little or no shear angle. Other types, that are harder to cut, need varying degrees of shear angle. Shear angle will be discussed further in the instructions for cutting various types of tile. The cutter is set at the factory with a slight degree of shear angle, which is proper for cutting .080" Gauge Vinyl Composition Tile.

Adjusting shear angle is quick and easy. Loosen the hex lock nut on each of the two bearing post thumb screws. If not in the closed position, pull the handle down so that the tip of the handgrip bears on the cutter table.

To change to greater shear angle, turn the right side thumb screw down one-half turn. The right side is the handle side. Then tighten the lock nut and proceed to make a cut. If cutting is easy, you have sufficient shear angle. If cutting is still a strain, then repeat the above procedure.

**IMPORTANT!** The right edge of the blade should always be lower than the left side when setting shear angle. Also, the cutter is factory set for shearing type cutting action, which means that the upper blade completely passes the lower blade in the closed position. Some types of tile require a breaking type of cutting action. This is achieved by adjusting the upper blade so that there is an opening between it and the lower blade when the cutter is closed. This is done by raising the bearing post thumb screws (as described above in setting shear angle). The types of tile requiring breaking will be mentioned in the following section.

# Instructions for Cutting Various Types of Tile

## Vinyl Composition Tile

In general, this depends on the thickness (.080",  $\frac{3}{32}$ ", and  $\frac{1}{8}$ ") and the temperature.

1. For .080" and  $\frac{3}{32}$ " thick tile: Can be sheared—cutter is set at the factory for these popular tiles. There is a slight shear angle in this setting (upper blade  $\frac{1}{32}$ " deeper at the handle side).
2. For  $\frac{1}{8}$ " thick tile: Can be sheared as above if temperature of tile is approximately 75°F or above. If cooler, tile tends to be brittle, then a breaking cutting action is desirable. How to adjust the upper blade for breaking action was described earlier. Approximately  $\frac{1}{32}$ " of opening should be left between the blades when in closed position, with a slight amount of shear angle.

## Solid Vinyl Tile, Rubber Tile, and Cork Tile

All of these materials require a shearing type cutting action. The thicker and tougher-to-cut materials require greater shear angle to make cutting easier. This is especially true if the cutter blades have become somewhat dull.

## Asphalt Tile and Epoxy Terrazzo Tile

Both of these materials require a breaking type of cutting action. The opening between the blades when the cutter is in the closed position should be about  $\frac{1}{32}$ " at the handle side and  $\frac{1}{16}$ " at the other side for  $\frac{1}{8}$ " thick tile. The opening (in the closed position) should be greater for thicker tile. A little bit of experimentation will result in the best setting.

## Carpet Tile

For cutting carpet tiles and other soft materials, adjust the No. H-24-23 Rear Support as follows:

1. Loosen four socket head cap screws and jam nuts.
2. Raise the rear support to the same height as the lower blade.
3. Tighten the socket head cap screws and jam nuts.

## General Information

The Ball Bearings on the handle crankshaft should be oiled (a few drops) occasionally.

When cutting, it is easier, and more natural to push down on the handle grip with the palm of the hand during the last portion of the cutting stroke.

The gauges, (Parts Nos. H-2445 and H-2490) are made for accurate 45° and 90° cuts. Full diagonal (45°) half tile cuts can be made on 12" x 12" Tile. For parallel cuts, be sure to hold the tile flush against the rail on the handle side of the cutter.

If you are not getting a perfect 45° angle when cutting diagonals, note the two hex socket set screws in the angled edge of the gauge that butts up against the tile. You may adjust these two screws in or out to achieve a perfect 45° angle.

# No. H-24 24" Tile Cutter

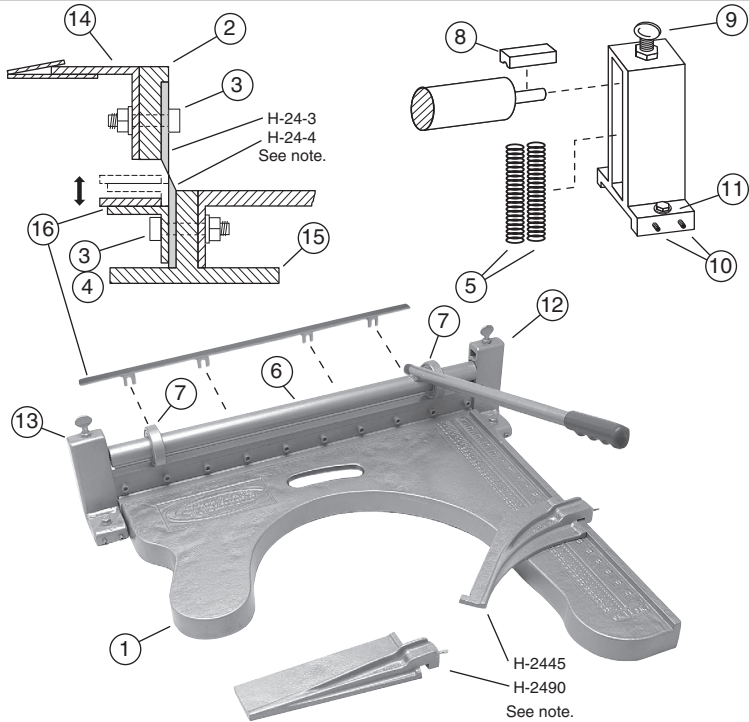

Key	Item Number	Qty. Used	Description
1	H-24-7	1	Base Casting
2	H-24-9	1	Upper Blade Bar
3	H-24-10	16	Blade Holding Screw Assembly (Includes Socket Head Cap Screw, Flat Washer, Split Lock Washer, and Jam Nut)
4	H-24-11	4	Blade Holding/Rear Support Screw Assembly (Includes Socket Head Cap Screw, Flat Washer, Split Lock Washer, and Jam Nut)
5	H-76-12	4	Coil Spring
6	H-24-13	1	Crankshaft and Handle with Grips
7	H-24-14	2	Crankshaft Ball Bearing
8	H-24-15	2	Crankshaft Cam Bearing
9	H-76-16	2	Thumb Screw with Nut
10	H-24-17	8	Post Adjusting Set Screw
11	H-24-18	4	Post Mounting Screw Assembly with Flat Washer and Lock Washer
12	H-24-19	1	Right Upper Blade Bar Post
13	H-24-20	1	Left Upper Blade Bar Post
14	H-24-21	1	Upper Blade Bar Stiffener
15	H-24-22	1	Lower Blade Bar Frame
16	H-24-23	1	Rear Support (Includes four 5/16-18 x 1¾" Socket Head Cap Screws)

**Note:** See current product catalog for the following parts:

- No. H-24-3 Upper Blade
- No. H-24-4 Lower Blade
- No. H-2490 Adjustable Straight Gauge with Screw
- No. H-2445 Adjustable Combination Straight/45° Gauge with Screw
- No. H-24-5 Casters with Screws (4/set)